

**Part Number: PT278-89100**

**Kit Contents**

Item #	Quantity Reqd.	Description
1	1	Front Crossbar Assembly
2	1	Rear Crossbar Assembly
3	1	Hardware Bag

**Hardware Bag Contents**

Item #	Quantity Reqd.	Description
1	2	Rubber Stoppers
2	4	M6 Wafer Head Screws

**Additional Contents**

Item #	Quantity Reqd.	Description
1		

**Conflicts**

Accessory Off-Road Roof Rack Side Rails
---

**Recommended Tools**

<b>Personal &amp; Vehicle Protection</b>	<b>Notes</b>
Safety Goggles	
Vehicle Protection	
Wrist & Belt Buckle Protectors	
<b>Special Tools</b>	<b>Notes</b>
<b>Installation Tools</b>	<b>Notes</b>
Nylon Removal Tool	
T25 Torx Head Screwdriver	
Torque Wrench	
T25 Torx Head Bit	
Tape Measure	
<b>Special Chemicals</b>	<b>Notes</b>

**NOTE:** Part number of this accessory may not be the same as the part number shown.

**General Applicability**

All Base and Limited Models with Factory Base Rails
---

**Recommended Sequence of Application**





Item #	Accessory
1	

\*Mandatory

**Vehicle Service Parts** (may be required for reassembly)

Item #	Quantity Reqd.	Description
1	1	RH Cover, Black P/N: 63493-35030
2	1	LH Cover, Black P/N: 63494-35030
3	1	RH Cover, Silver P/N: 63493-35040
4	1	LH Cover, Silver P/N: 63494-35040
5		
6		

**Legend**

	<b>STOP:</b> Damage to the vehicle may occur. Do not proceed until process has been complied with.
	<b>OPERATOR SAFETY:</b> Use caution to avoid risk of injury.
	<b>CAUTION:</b> A process that must be carefully observed in order to reduce the risk of damage to the accessory/vehicle and to ensure a quality installation.
	<b>TOOLS &amp; EQUIPMENT:</b> Used in Figures calls out the specific tools and equipment recommended for this process.
	<b>SAFETY TORQUE:</b> This mark indicates that torque is related to safety.

Care must be taken when installing this accessory to ensure damage does not occur to the vehicle. The installation of this accessory should follow approved guidelines to ensure a quality installation.

These guidelines can be found in the "Accessory Installation Practices" document.

This document covers such items as:-

- Vehicle Protection (use of covers and blankets, cleaning chemicals, etc.).
- Safety (eye protection, rechecking torque procedure, etc.).
- Vehicle Disassembly/Reassembly (panel removal, part storage, etc.).
- Electrical Component Disassembly/Reassembly (battery disconnection, connector removal, etc.).

Please see your Toyota dealer for a copy of this document.

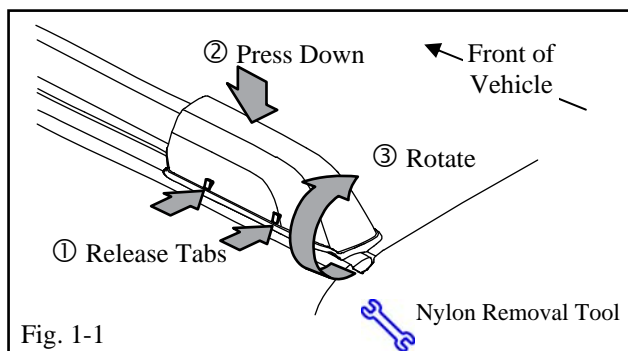

**1. Remove Rear Covers. (2 locations)**

- ⚠ (a) Carefully remove the rear covers. Using the nylon removal tool, ① pry cover outward tabs at locations shown. ② Press down the inward side ③ while rotating the cover. Set covers aside. (Fig. 1-1)

**Note:** Please see the **Vehicle Service Parts table on page 1 in the event of broken tabs for cover replacement.**

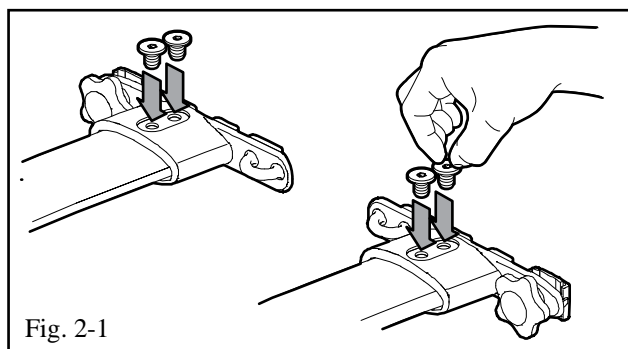

**2. Crossbar Installation.**

- ⚠ (a) Hand start (DO NOT TIGHTEN) M6 Wafer Head Screws on RH side of crossbars. (4 places) (Fig. 2-1)

- (b) Loosen the knobs on each crossbar joint. (4 places) (Fig. 2-2)

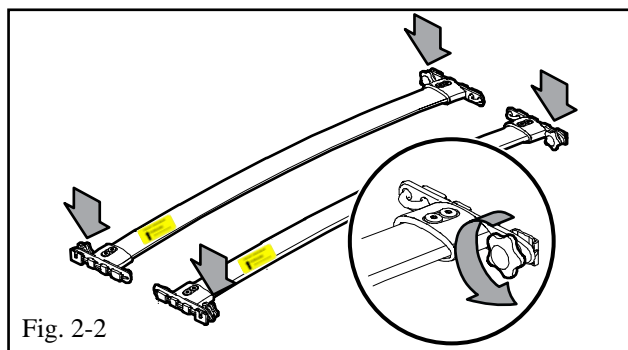

- ⚠ (c) Slide crossbars into rails with tie-down loops toward inside of vehicle. (Fig. 2-3)

**NOTE:** The crossbar ends are labeled LR (left rear), RR (right rear), LF (left front) and RF (right front) for reference.

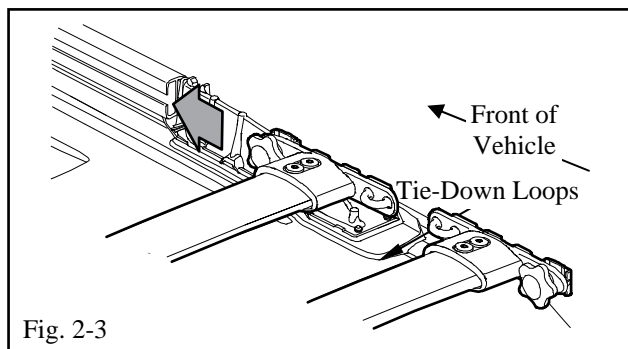

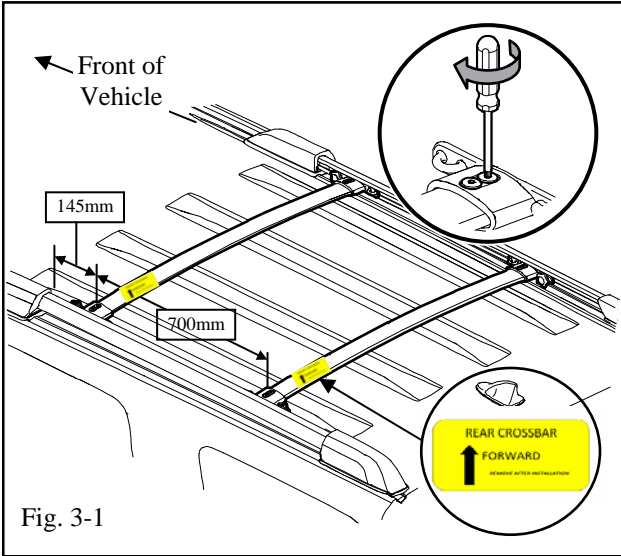



Fig. 3-1

**3. Position Crossbars**

- (a) Position front and rear crossbars so they are parallel. Front crossbar should be 145mm (5.7 in.) from the back of the front cover to the crossbar center. Rear crossbar should be 700mm (27.6 in.) from the front crossbar center to the rear crossbar center. (Fig. 3-1)
- (b) Securely tighten knobs

**NOTE: Owner should periodically verify knobs are tight, especially when carrying a load. Maximum load capacity is 60 kg (132 lbs.) evenly distributed.**

-  (c) Tighten RH side M6 wafer head screws using a T25 torx head screwdriver. Torque M6 wafer head screws to 1.8 N-m (15.9 lbf-in.). (Fig. 3-1)
- (d) Remove both front and rear yellow crossbar position labels and discard after proper assembly. (Fig. 3-1)

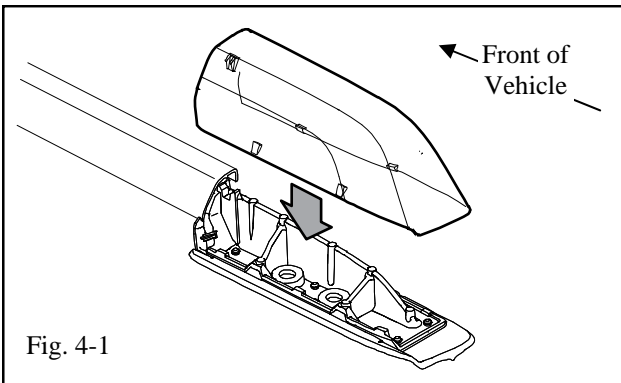



Fig. 4-1

**4. Re-install Rear Covers**

-  (a) Align clips with slots on base rail. Press down until cover snaps into position. (Fig. 4-1)

**NOTE: Confirm that the cover is installed securely.**

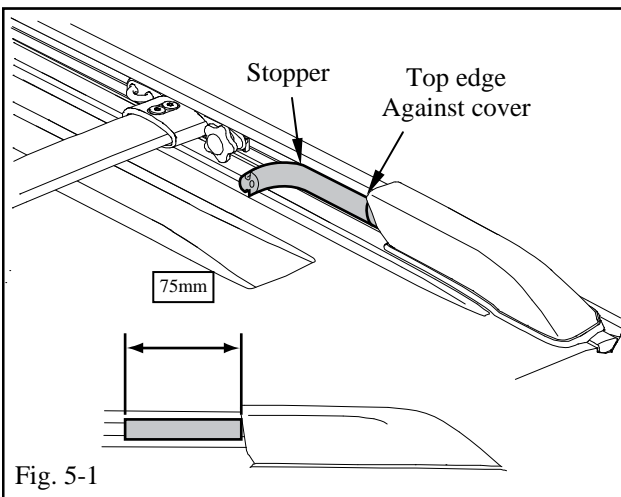



Fig. 5-1

**5. Stopper Installation**

-  (a) Install the stopper against the leg cover by pressing the stopper into the groove of the rail. Install on rear of rails both sides. (Fig. 5-1)

Checklist - these points **MUST** be checked to ensure a quality installation.

Check:

Look For:

Accessory Function Checks

- Ensure crossbars are secure and in correct position
  
- Ensure crossbars do not bind
  
- Ensure rear covers are securely attached

Crossbars knobs are tight and crossbars centers are at 145mm (5.7 in.) from front cover and 700mm (27.6 in) between crossbars.

Crossbars slide freely

Cover clips are fully engaged

Vehicle Function Checks