

Preparation

**Part Number: Mounting Kit PT546-89060
Tuner Assy 86180-0W031**

NOTE: Part number of this accessory may not be the same as the part number shown.

Tuner Assy Kit Contents (86180-0W031)

Item #	Quantity Reqd.	Description
1	1	TUNER ASSY, STEREO COMPONENT

Mounting Kit Contents (PT546-89060)

Item #	Quantity Reqd.	Description
1	1	Antenna
2	2	Bracket Ass'y SDARS Receiver
3	1	Wire, To Radio Installation
4	2	Base Bracket Ass'y SDARS Receiver
5	1	Ground Cord

Hardware Bag Contents 1 (PT546-89060)

Item #	Quantity Reqd.	Description
1	2	Cushion Tape (100mm×50mm)
2	6	Lock Tie A
3	1	Template
4	1	Butyl cushions

Hardware Bag Contents 2 (PT546-89060)

Item #	Quantity Reqd.	Description
1	4	Screw (M5×L8)
2	4	Nut (M6)

Hardware Bag Contents 3 (PT546-89060)

Item #	Quantity Reqd.	Description
1	1	Housing
2	1	Template
3	7	Nylon Tape (30mm×30mm)
4	1	Lock Tie B
5	4	Cable Rail (150mm)
6	1	Cable Rail (20mm)
7	1	Cable Rail (10mm)
8	1	Cushion Tape (40mm ×80mm)

Additional Items Required For Installation

Item #	Quantity Reqd.	Description

Conflicts

Sirius Satellite Radio, iPod Interface and Tom Tom Navigation Audio

Recommended Tools

Personal & Vehicle Protection	Notes

Safety Goggles	
Seat Covers	
Floor Protectors	
Special Tools	Notes
None	
Installation Tools	Notes
Wrench	Open End, 10mm
Socket	10mm, 12mm, 14mm
Phillips Screwdriver	
Nylon Removal Tool	
Torque Wrench	4.1 N-m (3 lbf-ft), 42 N-m (31 lbf-ft), 37 N-m (27 lbf-ft)
Utility Knife	
Masking Tape	
Special Chemicals	Notes
Cleaner	3M™ Prep Sol-70

General Applicability

--

Recommended Sequence of Application

Item #	Accessory
1	
2	

*Mandatory

Vehicle Service Parts (may be required for reassembly)

Item #	Quantity Reqd.	Description
1		
2		

Legend



STOP: Damage to the vehicle may occur. Do not proceed until process has been complied with.



OPERATOR SAFETY: Use caution to avoid risk of injury.



CAUTION: A process that must be carefully observed in order to reduce the risk of damage to the accessory/vehicle and to ensure a quality installation.



TOOLS & EQUIPMENT: Used in Figures calls out the specific tools and equipment recommended for this process.



REVISION MARK: This mark highlights a change in installation with respect to previous issue.



SAFETY TORQUE: This mark indicates that torque is related to safety.

Parts Description of Tuner Assy (86180-0W031)

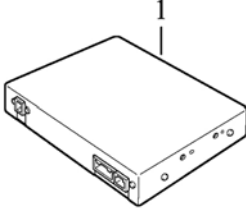

Item #	Parts Name	Parts No.	Qty
1	Tuner	86180-0W030	1

Parts Description of Mounting Kit (PT546-89060)

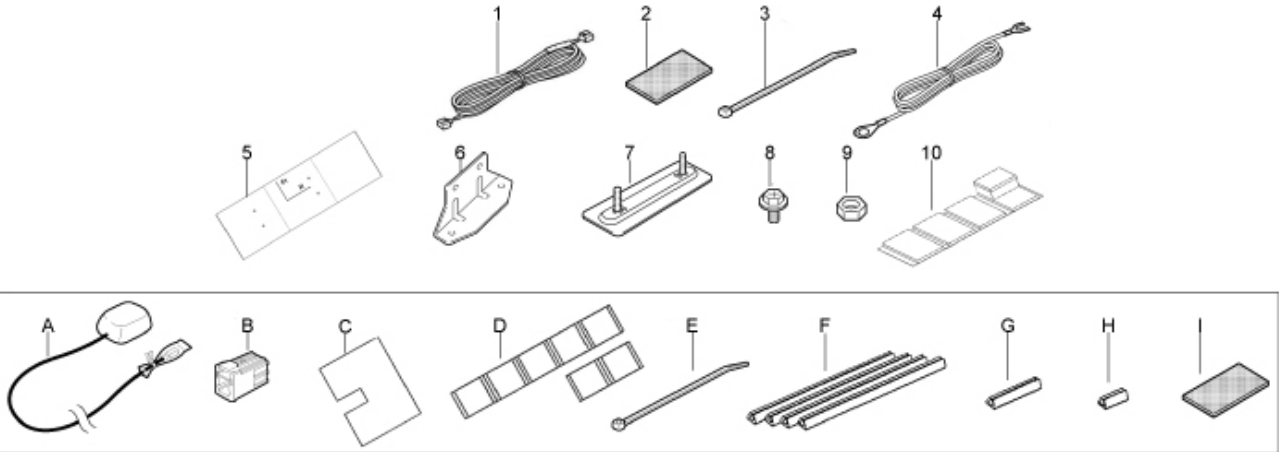

Item #	Parts Name	Parts No.	Qty
1	Wire, To Radio Installation		1
2	Cushion Tape (100mm x 50mm)		2
3	Lock Tie A		6
4	Ground cord		1
5	Template		1
6	Bracket Ass'y SDARS Receiver		2
7	Base Bracket Ass'y SDARS Receiver		2
8	Screw (M5 x L8)		4
9	Nut (M6)		4
10	Butyl Cushions		1
11	A	Antenna	1
	B	Housing	1
	C	Template	1
	D	Nylon Tape (30mm x30mm)	7
	E	Lock Tie B	1
	F	Cable Rail (L=150mm)	4
	G	Cable Rail (L=20mm)	1
	H	Cable Rail (L=10mm)	1
	I	Cushion Tape (80mm x 40mm)	1

Care must be taken when installing this accessory to ensure damage does not occur to the vehicle. The installation of this accessory should follow approved guidelines to ensure a quality installation.

These guidelines can be found in the "Accessory Installation Practices" document.

This document covers such items as:-

- Vehicle Protection (use of covers and blankets, cleaning chemicals, etc.).
- Safety (eye protection, rechecking torque procedure, etc.).
- Vehicle Disassembly/Reassembly (panel removal, part storage, etc.).
- Electrical Component Disassembly/Reassembly (battery disconnection, connector removal, etc.).

Please see your Toyota dealer for a copy of this document.

1. Remove the Negative (-) Battery Cable. (Fig. 1-1):

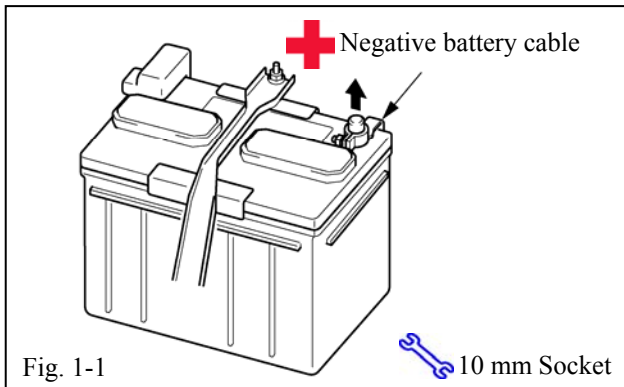

(a) Protect the fender before removing the battery cable.



(b) Be careful not to touch the positive terminal.

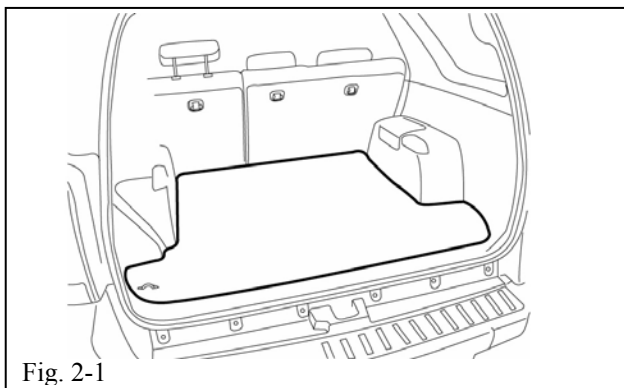

2. Disassembly of Rear Cargo Area.

(a) Remove the trunk mat. (Fig. 2-1)

(b) Remove the rear scuff trim. (Fig. 2-2)

(c) Remove the rear deck board (Fig 2-2)

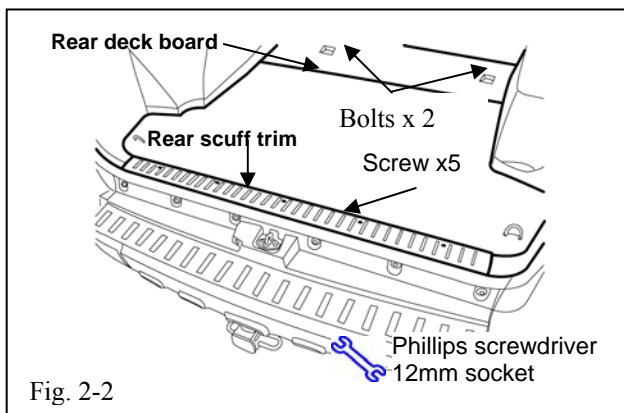

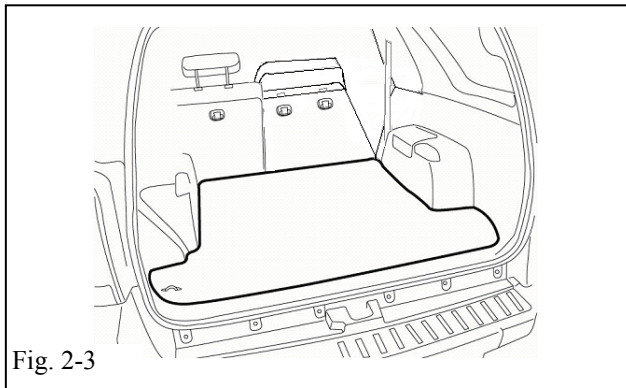

(d) Rear right seat (Fig. 2-3)

- (1) Remove rear right seat back headrests.
- (2) Fold seat bench forward by lifting rear of seat forward.
- (3) Pull the rear seatback release button and tilt the rear right seat back forward.

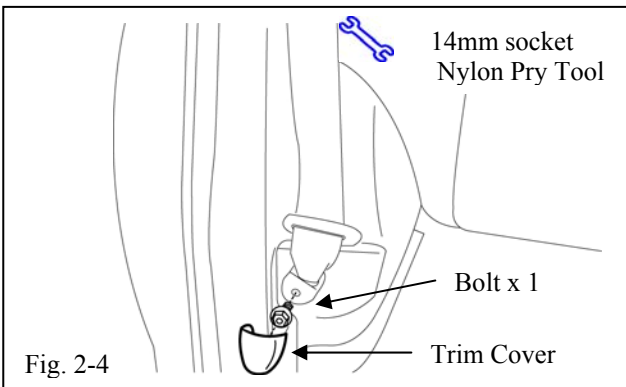

(e) Remove RR Seat Belt Anchor and Trim Cover. (Fig 2-4)



NOTE: Use protective cloth and tape to cover seat belt anchor after removal.

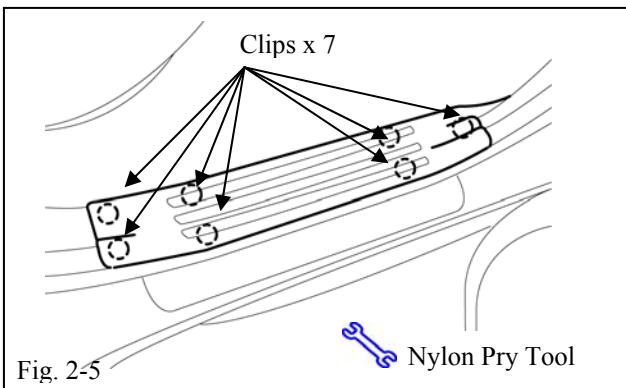

(f) Remove rear right door scuff plate. (Fig 2-5)

(g) Remove the right rear trim panel. (Fig. 2-6)

- (1) Remove 2 bolts as shown. Fold back right rear cargo area carpet and remove 3 screws securing quarter panel trim.
- (2) Using Nylon Pry Tool remove the plastic plugs as shown.
- (3) Disconnect the auxiliary power jack.

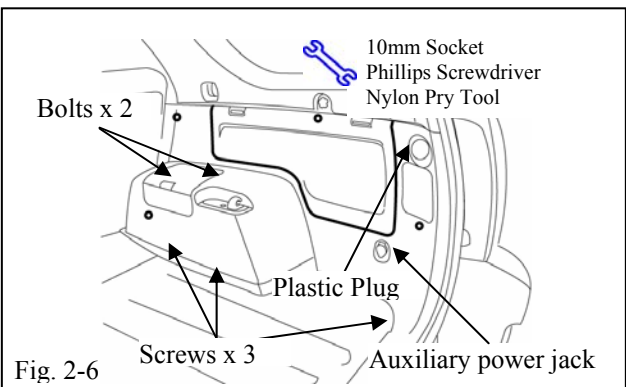

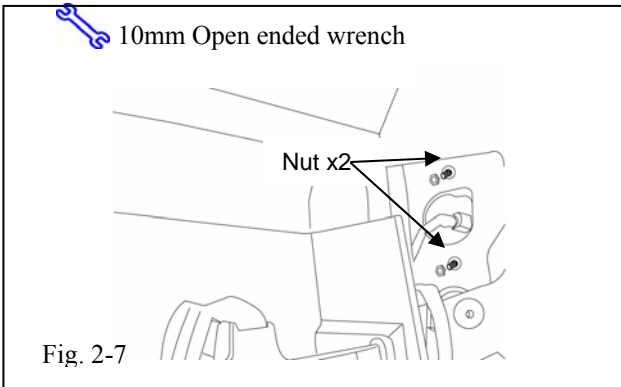

(h) Remove the taillight

- (1) From the inside corner, remove the tail lamp nuts, disconnect the harness connector, then remove the tail lamp assembly. (Fig. 2-7)

3. Disassemble Vehicle Interior

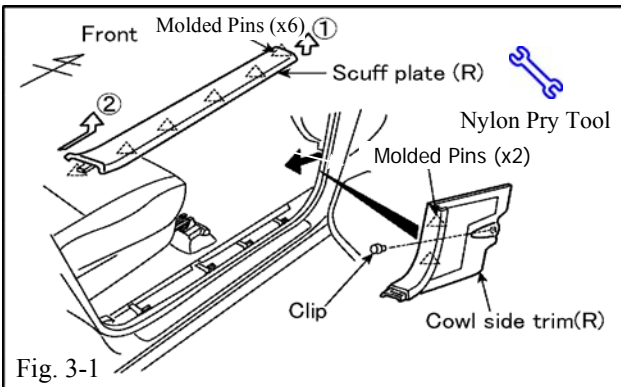

(a) Remove the front right scuff plate and cowl side trim.

- (1) Remove the right scuff plate, and then remove the cowl side trim (R). (Fig 3-1)
- (2) Remove the scuff plate in order from front (①) to rear (②) using a nylon pry tool.
- (3) Remove the cowl side trim, secured by one (1) clip and two (2) molded pins.

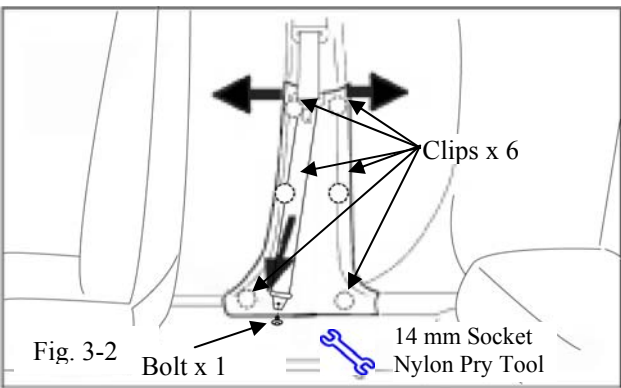

(b) Remove front seat belt anchor and B-pillar trim panel. Fig. (3-2)

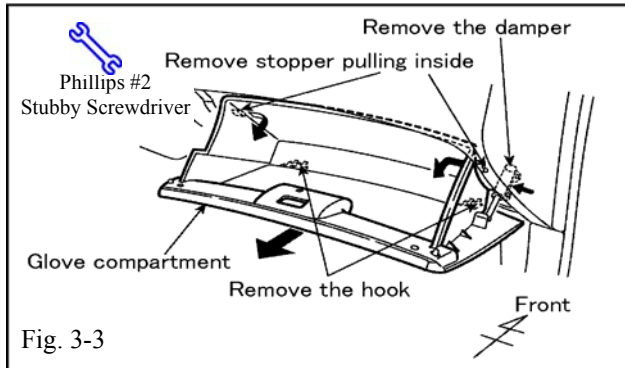

(c) Remove the glove compartment door.

- (1) Release the glove compartment stoppers by pressing both glove box side panels inward. (Fig. 3-3)
- (2) Remove the damper, using a Phillips #2 stubby screwdriver.
- (3) Remove the glove box from the hinge hooks on the rear.

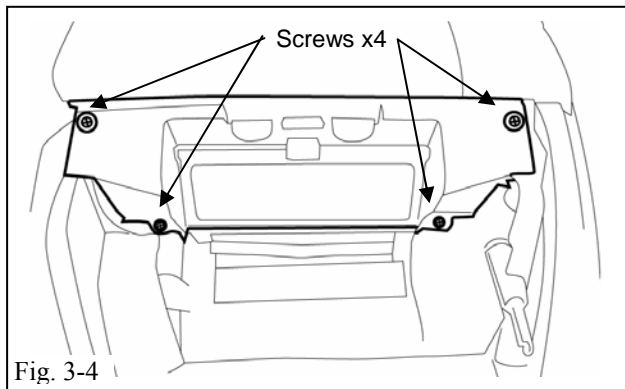

(d) Remove the upper glove box.

- (1) Remove the screws, then pull the upper glove box trim outward to access the SRS harness connector. (Fig. 3-4)
- (2) Push the SRS harness bracket clips inward to release the bracket from the glove box trim. (Fig. 3-5)
- (3) Disengage the SRS harness connector bracket, and then remove the upper glove box.

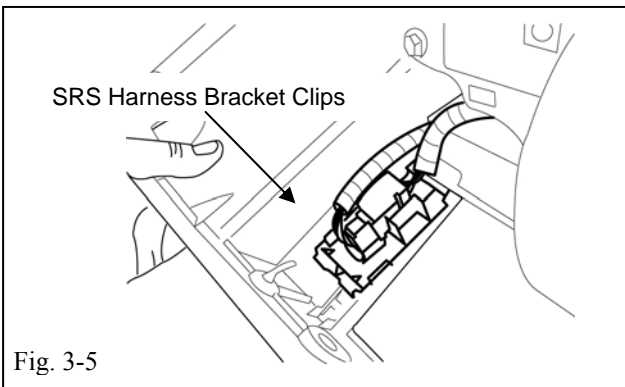

(e) Remove Shift Cover, Side Covers and Coin Box. (Fig. 3-6)

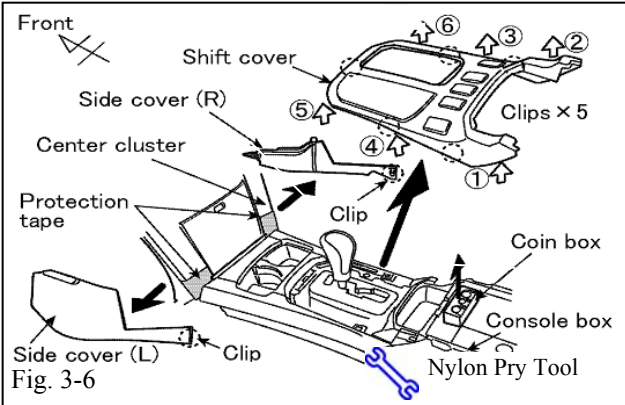

- (1) Protect center cluster with the tape to avoid the damage to center cluster when removing console box.
- (2) Remove the shift cover in order from ① to ⑥ using a nylon pry tool.
- (3) Use the nylon pry tool to disengage the clip under the left side cover (L).
- (4) Use the nylon pry tool to disengage clip under the right side cover (R).
- (5) Unplug the connector.

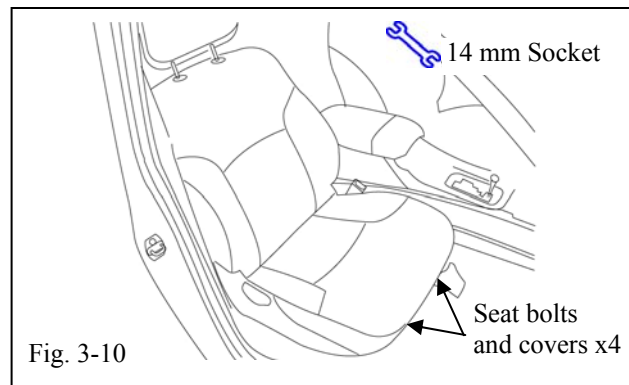
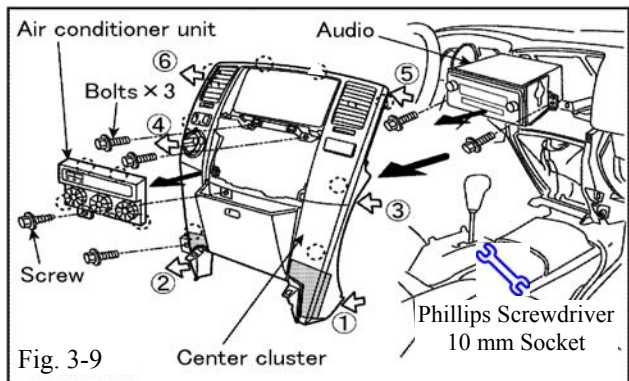
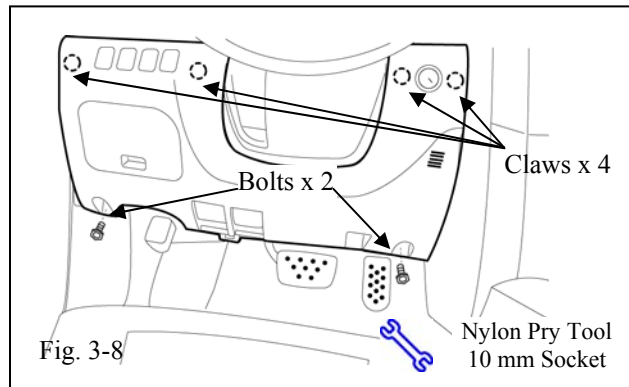
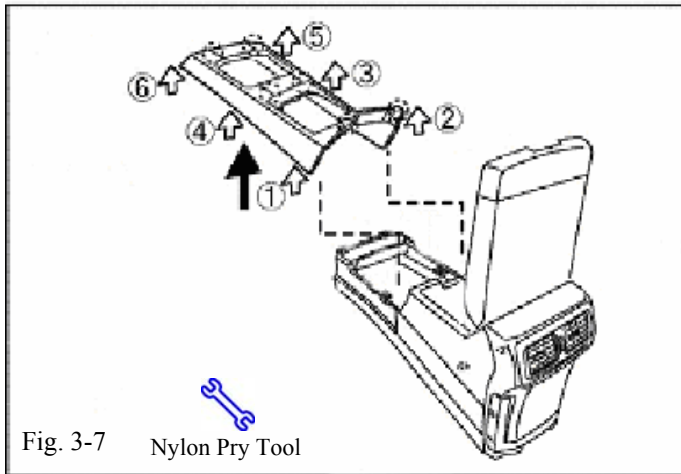

- (f) Remove the Center Console Cover.
 - (1) Use nylon pry tool to disengage six clips on rear cover as shown. (Fig. 3-7)
- (g) Remove driver's side underdash trim panel. (Fig. 3-8).
 - (1) The dash panel must be removed to access the center console bolt.
 - (2) Remove 2 bolts as shown.
 - (3) Disengage 4 claws using Nylon Pry Tool.
- (h) Remove the air conditioner unit. (Fig. 3-9)
 - (1) Remove the screw on air conditioner unit with a Phillips screwdriver.
 - (2) Remove plug from cluster.
 - (3) Remove two (2) plugs from the center cluster.
- (i) Remove the Audio Unit (Fig. 3-9)
 - (1) Using a 10 mm socket, remove two bolts on the audio unit.
 - (2) Remove the connectors from the rear of the unit.
- (j) Remove the Front Passenger Seat.
 - (1) Remove the covers and bolts (x4) from the front passenger seat mounting bracket, then tilt the seat backwards. (Fig.s 3-10 and 3-11)

NOTE: Do not disconnect the harness from the seat or remove the seat from the vehicle.

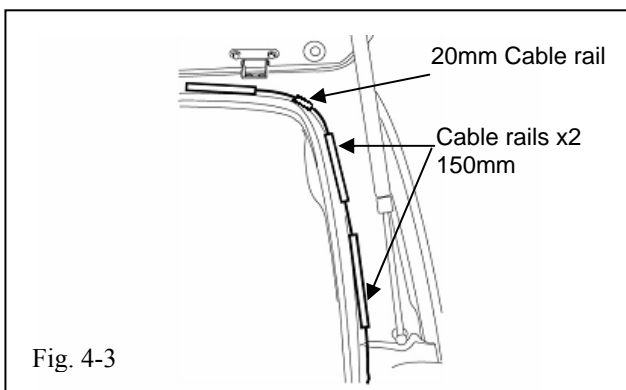
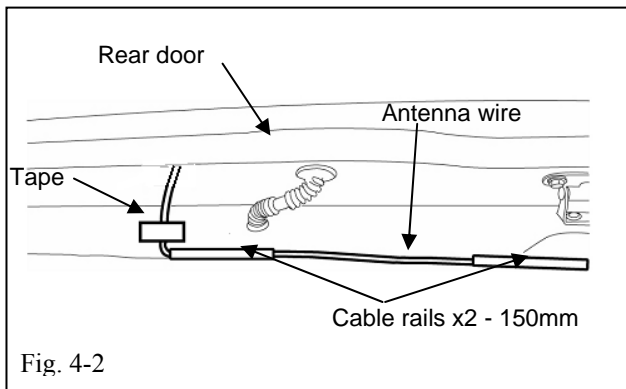
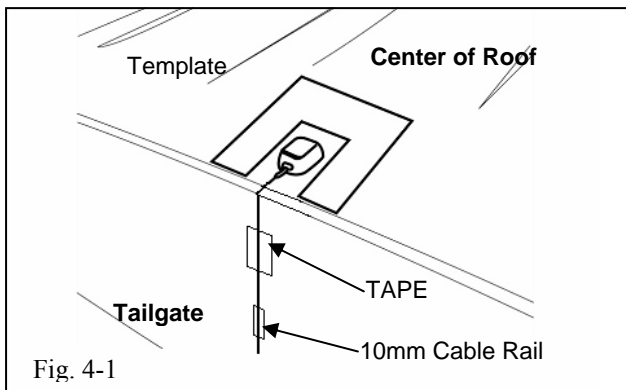
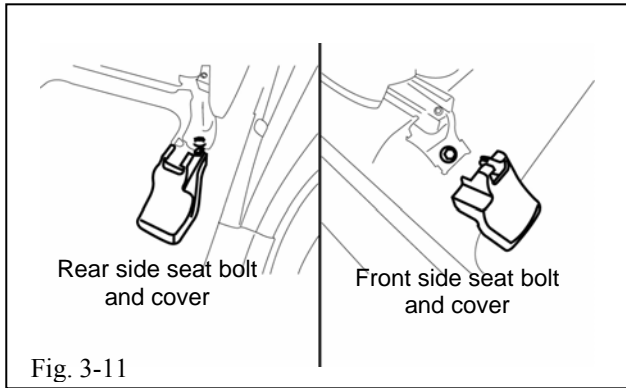

4. Antenna Installation

- ⚠ (a) Carefully clean the mounting surface for the template, antenna, tape, and cable rails (using 3M™ Prep Sol-70 and cleaning method).
- (b) Tape the antenna mounting template onto the rear roof section. (Fig. 4-1)
 - (1) Remove the backing from the antenna, and then install the antenna onto the roof along the template guide lines. Remove and discard the template.
- (c) Route the antenna wire as follows.
 - (1) Route the antenna wire into and along the rear door channel toward the RR tail lamp to route the antenna wire as shown. (Fig. 4-2, Fig. 4-3)

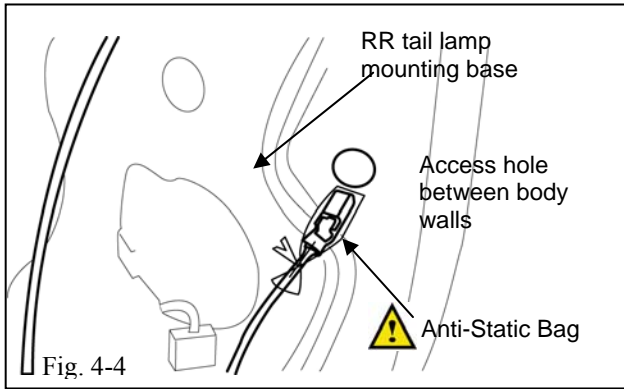

- (d) Insert the antenna wire through the access hole in the tail lamp mounting base and into the vehicle interior. (Fig. 4-4)

NOTE: Do not take off Anti-Static Bag until antenna terminal is plugged into Satellite Receiver.

- (1) Slide grommet to remove any slack.
- (2) Plug the access hole with the rubber grommet supplied with the antenna wire.
- (3) Tape the antenna wire in the tail lamp area as shown. (Fig. 4-5)

NOTE: Carefully clean any tape mounting surface, (using 3M™ Prep Sol-70 and cleaning method).

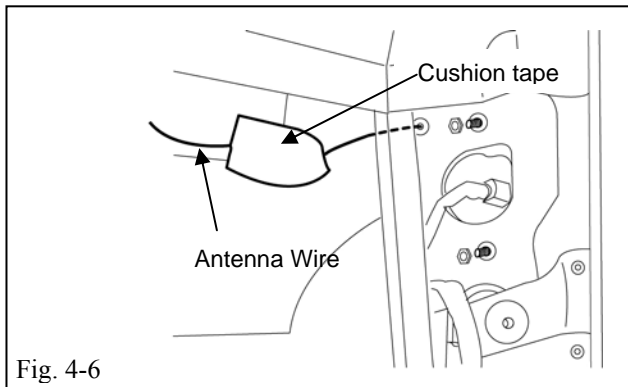
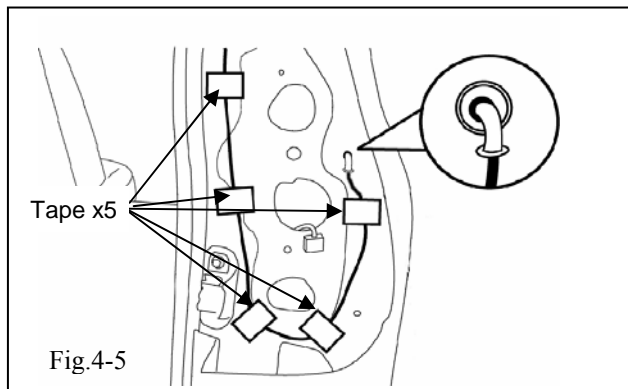

- (e) Cut the supplied foam cushion tape in half.
- (f) Remove excess antenna slack, then secure to the body panel with ½ cushion tape as shown. (Fig. 4-6)
- (g) Route the antenna wire along the right rear body panel with the windshield washer hose and using existing wire clips. Apply ½ foam cushion tape to the body panel at location shown. (Fig 4-7)

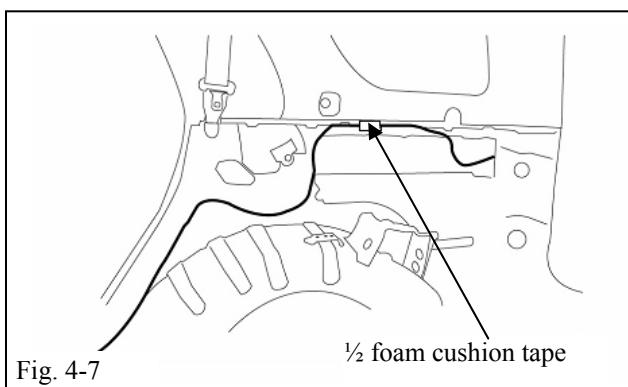

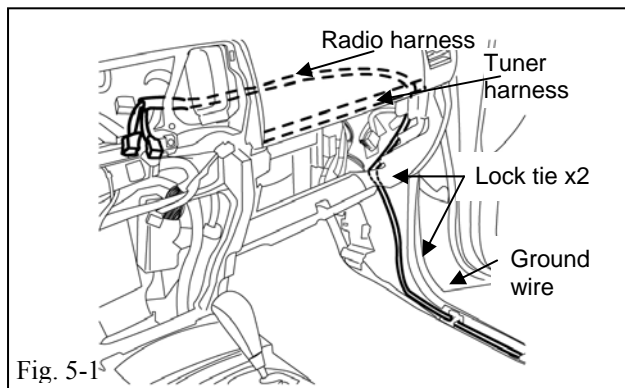
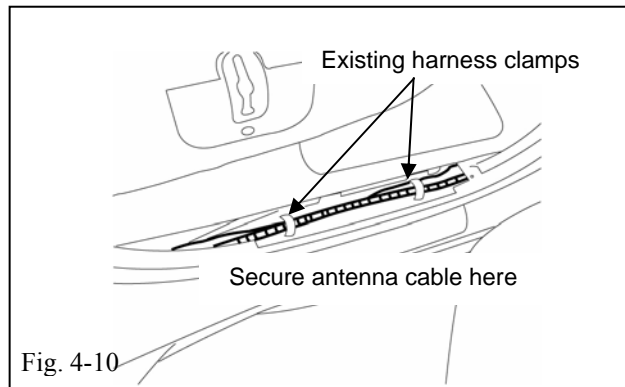
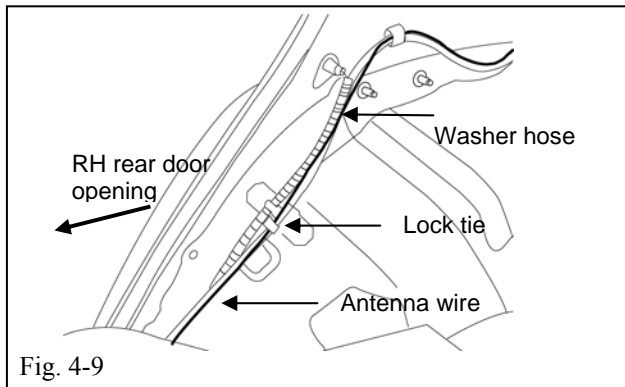
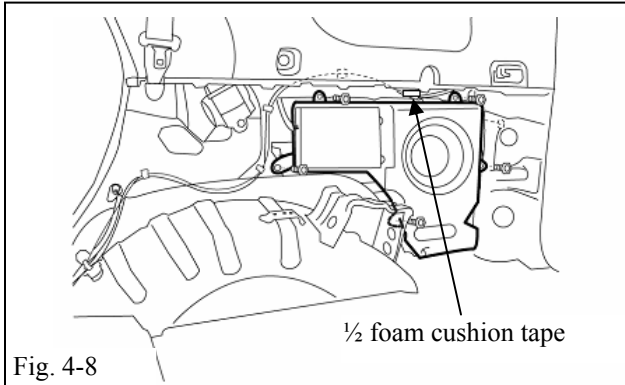

If equipped with optional subwoofer.

NOTE: Apply 1/2 foam cushion tape to the existing wire harness if equipped with subwoofer assy. (Fig 4-8)

(h) Route the antenna wire with the rear window washer hose along the RR door sill. Stop at the B-pillar. (Figs 4-9, 4-10)

(i) Route antenna wire along existing wire harness along wheel well. Lock tie to existing harness. (Fig 4-9)

(j) Secure antenna wire under the existing harness clamps on the RR rear door sill. (Fig. 4-10)

5. Install the Tuner Harness and Ground Wire.

(a) Install the Tuner Harness

(1) Starting from the cowl side area, route the tuner harness upwards into the glove box area above the reinforcement bar, then into the center opening. (Fig 5-1, 5-2, and 5-3)

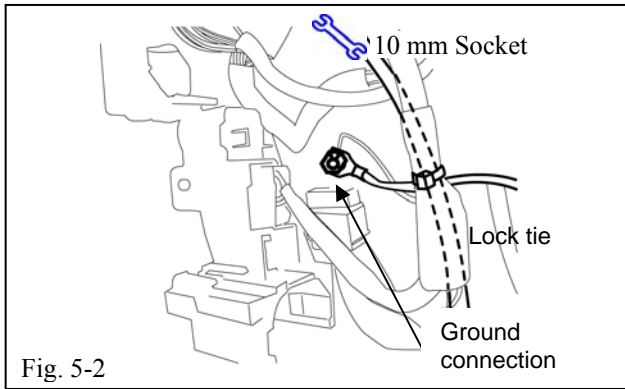

(b) Install the Ground Wire.

- (1) Route the ground wire into the cowl side trim area, then attach the ground terminal onto the existing ground screw as shown (Fig 5-2)

(c) Install lock ties.

- (1) Install 1 Lock Tie to secure the tuner harness to the existing harness.

(Fig. 5-2)

- (2) Install 2 Lock Ties to secure the tuner harness to the existing harness.

(Fig. 5-3)

- (3) Install 1 Lock Tie to secure the tuner harness to the existing harness.

(Fig. 5-4)

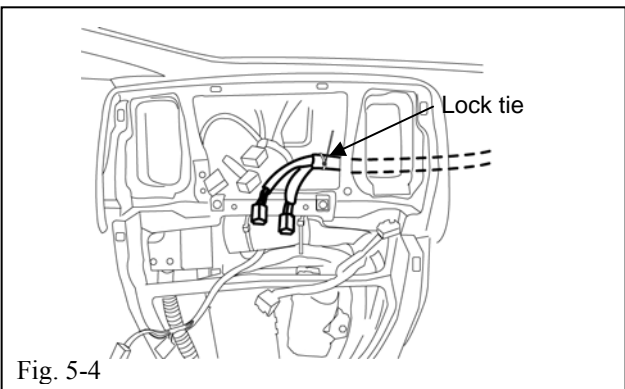
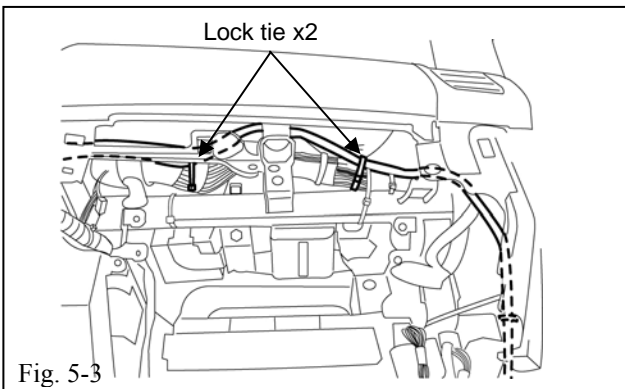

6. Install the Tuner and Harness

- +** (a) Cut the carpet opening at the location shown to allow the seat harness to be moved without damaging connectors to the seat. (Fig. 6-1)

STOP NOTE: Be careful not to cut seat harness

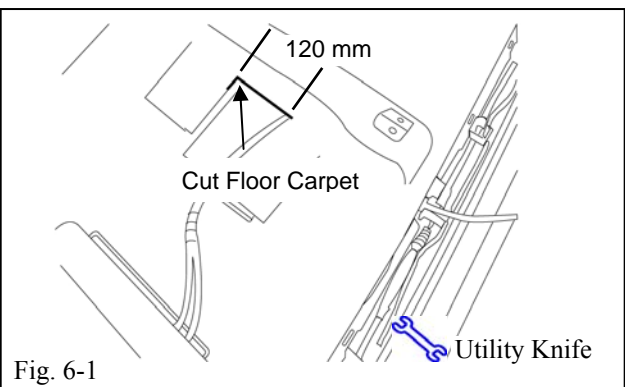

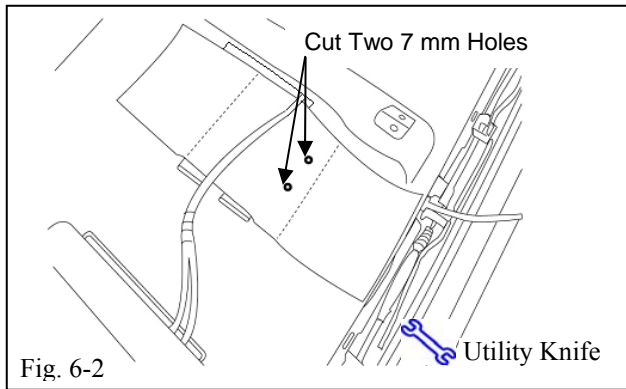

- (b) Align the template on the carpet. Using the existing cut along the side of the heater duct place the left mounting bracket at this location. Using the bracket as a template, transfer the hole locations to the carpet then cut two 7 mm holes onto the carpet. (Fig. 6-2)

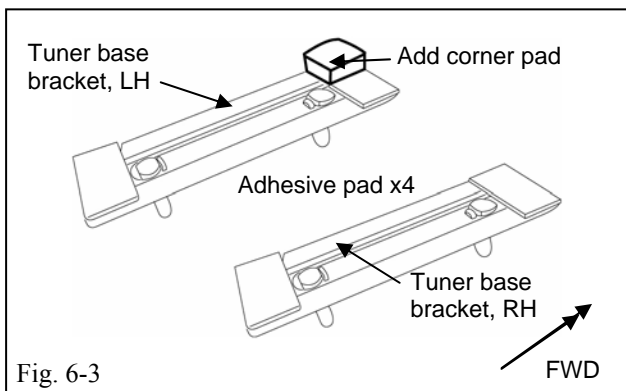

- (c) Add butyl cushions spacers (adhesive pads) to the tuner base brackets. (Fig. 6-3)

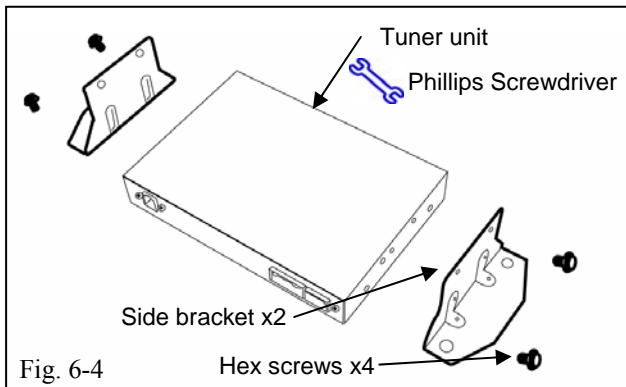

- (d) Assemble the side brackets onto the tuner. (Fig. 6-4)

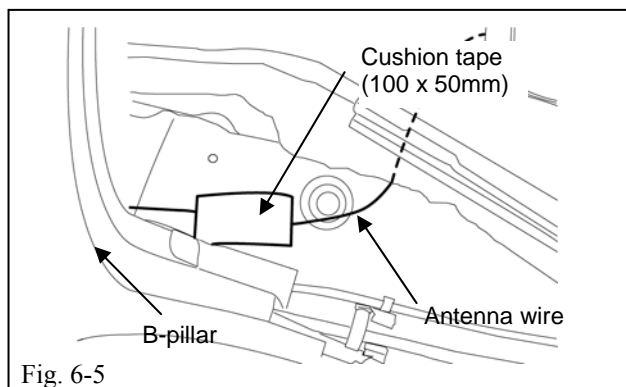

- (e) Route the antenna wire from the B-Pillar area toward the tuner mounting area, then tape the antenna wire in place as shown. (Fig. 6-5)
- (f) Route the tuner harness and ground wire along the rear right door scuff plate channel then toward the tuner mounting area.

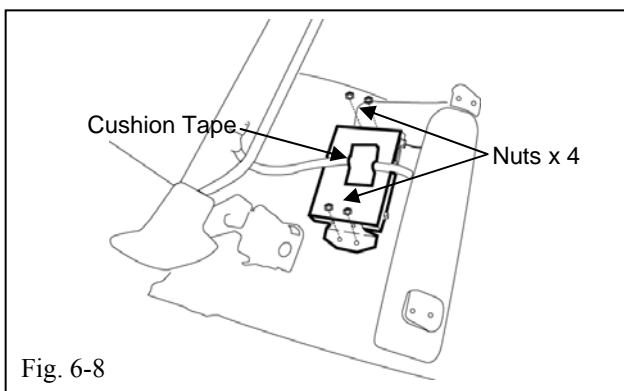
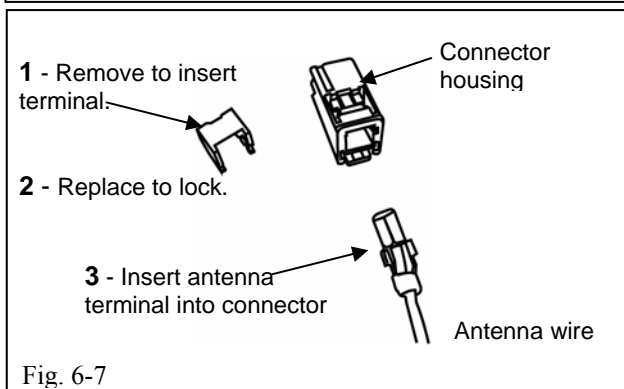
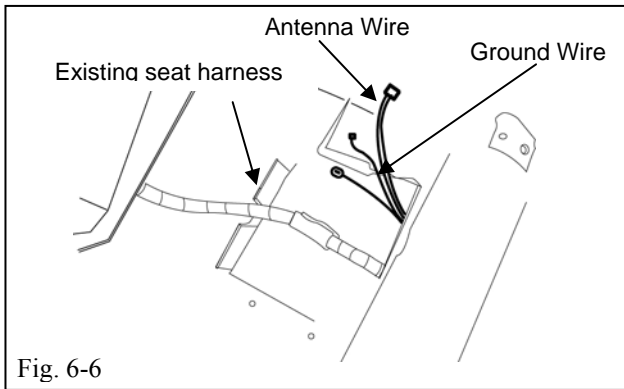

(g) Route harness and wires to the tuner mount area. (Fig. 6-6)

(1) Relocate the existing seat harness into the new opening shown.

NOTE: Route the tuner harness, antenna wire and ground wire through carpet openings.

(h) Take off Anti-Static bag and insert the antenna terminal into the connector housing. (Fig. 6-7)

(i) Install the tuner unit. (Fig. 6-8)

! **NOTE:** Trial fit the tuner before mounting in place.

! (1) Carefully clean the mounting surface, (using 3M™ Prep Sol-70 and cleaning method).

(2) Remove the adhesive backing from each tuner base bracket, then install onto the floor of the vehicle with the studs sticking up through the carpet openings.

! (3) Install the tuner onto the base brackets as shown using the M6 nuts. (Fig. 6-8)

(4) Install the ground wire terminal under one of the side bracket screws.

(5) Plug the tuner cable and antenna cable into the tuner unit.

(6) Tape the existing seat harness to the top of the tuner. (Fig. 6-8)

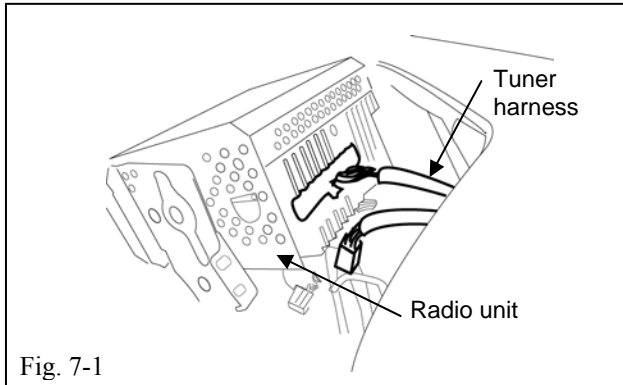

Fig. 7-1

7. Re-install the Radio Unit

- ⚠ (a) Plug the tuner connector into the radio unit, and then reinstall the radio. (Fig. 7-1)
- ⚠ (b) If the vehicle is equipped with other options, such as any radio controlled unit, use and connect the other harness connectors from the additional modules to the radio unit.

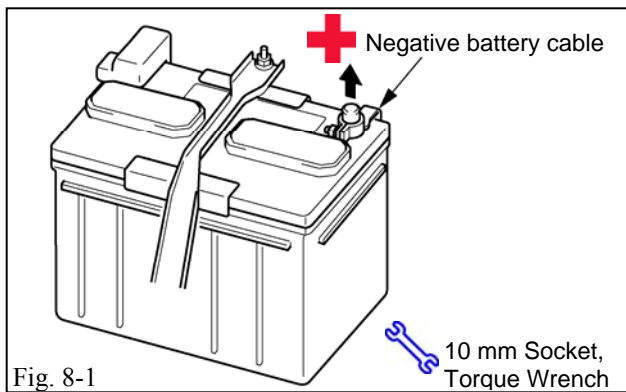

Fig. 8-1

8. Reconnect the Negative Battery Cable.

- (a) Reconnected the vehicle's negative battery cable at original factory position. (Fig. 8-1)
 - (1) Tighten the nut to 36 lbf in. (4.1 N-m)
 - ⊕ (2) Do not touch the positive terminal with any tool when replacing the cable.

9. Proceed to Checklist (page 15)

- (a) Complete checklist before reassembly of vehicle.

10. Reassembly

- (1) Reassemble the removed panels and connectors.
- ⚠ (2) Reinstall the front seat bolts. Specified tightening torque: 37 N-m (375 kgf-cm) (27 lbf-ft)
- ⚠ (3) Reinstall seat belt anchor bolts: Specified tightening torque: 42 N-m (430 kgf-cm) (31 lbf-ft)

<u>Check:</u>	<u>Look For:</u>
<p><u>Accessory Function Checks</u></p> <ul style="list-style-type: none"><input type="checkbox"/> Verify the proper operation of the satellite radio tuner. Refer to the tuner assembly and radio owner's manuals.<input type="checkbox"/> Verify the proper operation of the tuner assembly and radio. Refer to the tuner assembly and radio owner's manuals.	
<p><u>Vehicle Function Checks</u></p> <ul style="list-style-type: none"><input type="checkbox"/> Verify the proper operation of the hazard switch.<input type="checkbox"/> Verify the removed seat is securely fastened.<input type="checkbox"/> Verify the proper operation of the removed seat lock mechanism.<input type="checkbox"/> Verify the proper operation of the air conditioning system.<input type="checkbox"/> Verify the proper operation of the multi-information displays.<input type="checkbox"/> Verify the proper operation of the R/R taillight assembly.<input type="checkbox"/> Verify the proper operation of the rear 12V auxiliary power jack.<input type="checkbox"/> Verify the proper operation of the 4WD switch.<input type="checkbox"/> Verify the proper operation of the Rear window switch.<input type="checkbox"/> Verify the proper operation of the differential lock switch.<input type="checkbox"/> Verify the proper operation of the seat heaters.	